

# DETAIL DRAWING

**YA-50.**

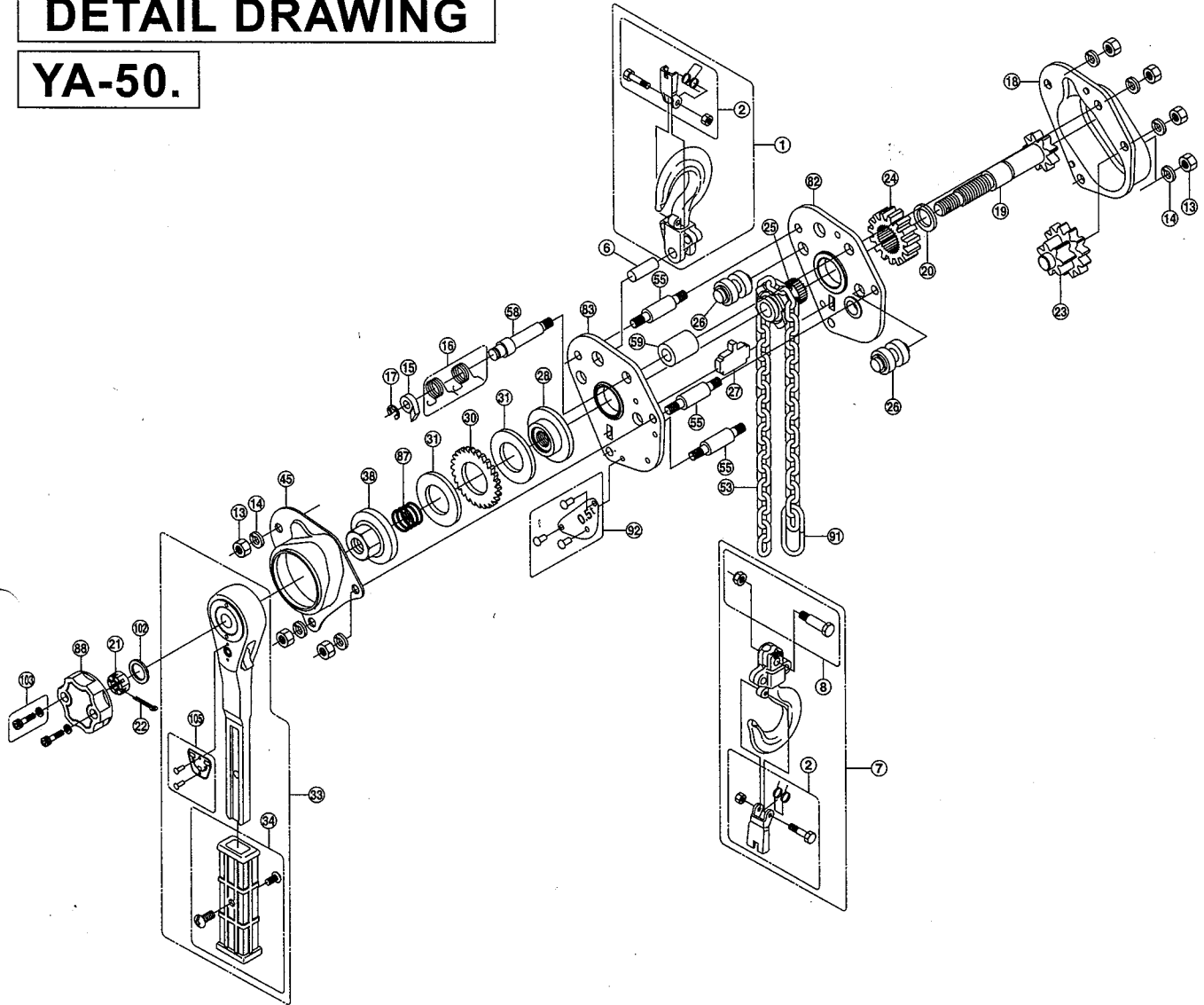

## YA-50

- |                           |                                  |
|---------------------------|----------------------------------|
| ① Top hook ass'y          | ②⑧ Disc hub                      |
| ② Safety latch set        | ⑩ Ratchet wheel                  |
| ⑥ Top hook pin            | ⑪ Brake lining                   |
| ⑦ Bottom hook ass'y       | ⑫ Lever ass'y                    |
| ⑧ Chain stop bolt set     | ⑬ Lever grip set                 |
| ⑬ Hex. nut                | ⑭ Female screw                   |
| ⑭ Spring washer           | ⑮ Brake cover                    |
| ⑮ Pawl                    | ⑯ Load chain set                 |
| ⑯ Pawl spring             | ⑰ Stay bolt                      |
| ⑰ E-ring for pawl         | ⑱ Ratchet pin                    |
| ⑱ Gear cover ass'y        | ⑲ Stay pipe                      |
| ⑲ Pinion shaft            | ⑳ Gear-side plate ass'y          |
| ⑳ Washer for pinion shaft | ㉑ Lever-side plate ass'y         |
| ㉑ Hex. castle nut         | ㉒ Spring for floating mechanism  |
| ㉒ Cotter pin              | ㉓ Feed handle                    |
| ㉓ 2nd and 3rd gear ass'y  | ㉔ Chain stopper                  |
| ㉔ Load gear               | ㉕ Name plate                     |
| ㉕ Load sheave             | ㉖ Check Washer                   |
| ㉖ Chain guide ass'y       | ㉗ Hex. socket head cap screw set |
| ㉗ Chain stripper          | ㉘ Direction plate                |