

PFR Permanent lifting magnet	180
QPM Permanent lifting magnet	182
Hand- and compact crane magnet	184



- 0.3 mm		$\Delta < 0.3 - 0.5$ mm	
Mmax. [kg]	Lmax. x Wmax. (mm x mm)	Mmax. [kg]	Lmax. x Wmax. (mm x mm)
L>400 W>400	L>120 W>245	L>400 W>400	L>120 W>245
380	370	255	250
320	290	220	200
1250	195	1400 x 1000	150
1250	95	1750 x 1000	80
x 1250	220	2150 x 1000	165
x 1250	160	2150 x 1000	125
x 1250	100	2000 x 1000	80
x 3500	200	Lmax. 3000	150

REMA[®]
HOLLAND
PFR 500

PFR permanent lifting magnets



REMA PFR permanent lifting magnets are manufactured from neodymium magnetic material resulting in very powerful lifting magnets in relation to the own weight and dimensions. REMA PFR permanent lifting magnets are suitable for both round and flat workpieces.

Properties

- Safety factor 3.
- Powerful Neodymium magnet material.
- Very high lifting capacity.
- Easy operation.
- Light mechanical operation with safety lever.
- Large lifting eye.
- Compact design.
- Low own weight.
- Robust construction of house and magnet.

Application

- Workshops, warehouses and machine tools such as cutting, milling, grinding and sawing machines, bending machines and lathes.

Option

- Tilt arm for PFR 250 (3601013) and PFR500 (3601015)

Norm:

- EN12100-1/2, EN13155

Type	S.W.L. (kg)	Safe working load round material (kg)	Material thickness (mm)	max dimensions plate (L x B) (mm)	Dimensions L x W x H (mm)	Diameter range (mm)	Weight (kg)	ProductId
PFR-125	125	50	25	1900 x 500	95 x 60 x 110	50-100	3.0	3601004
PFR-250	250	125	30	1750 x 1000	151 x 100 x 168	60-200	10.0	3601005
PFR-500	500	250	40	1800 x 1500	246 x 120 x 168	65-270	19.0	3601007
PFR-1000	1000	500	60	2450 x 1500	316 x 148 x 216	100-300	37.0	3601009
PFR-1500	1500	750	60	2450 x 1500	410 x 165 x 253	150-350	50.0	3601010
PFR-2000	2000	1000	80	3250 x 1500	480 x 165 x 251	100-350	85.0	3601011

HA lifting arm to lift and turn plates with PFR



For lifting and tilting steel plates up to 500 kg.
From horizontal to vertical.

Properties

- HA-250 for plates with a width of 250-800 mm and a length of 200-1500 mm.
- HA-500 for plates with a width of 250-1000 mm and a length of 250-2000 mm.

Application

- The tilting of steel plates in warehouses and workshops.



Type	S.W.L. (kg)	Dimensions L x W x H (mm)	Weight (kg)	ProductId
HA-250	250	960 x 210 x 255	17	3601013
HA-500	500	1160 x 275 x 255	19	3601015

PFR Capacity table



Safe working load limit for flat steel sheets (S 235 JR [ST-37])

Type	Material thickness (mm)	clean and smooth surface air gap 0.1 mm			rusty / hot rolled surface air gap 0.1 - 0.3 mm			irregular and rough surface air gap 0.3 - 0.5 mm			very rough surface air gap > 0.5 mm
		Max. dim. (mm)	WLL (kg) for plate dimensions below		Max. dim. (mm)	WLL (kg) for plate dimensions below		Max. dim. (mm)	WLL (kg) for plate dimensions below		
PFR 125		(L x B)	L > 200 B > 200	L > 60 B > 100	(L x B)	L > 200 B > 200	L > 60 B > 100	(L x B)	L > 200 B > 200	L > 60 B > 100	
	≥ 25	-	125	110	-	75	70	-	60	55	
	15	1900 x 500	115	100	1100 x 500	70	60	900 x 500	55	45	
	10	2300 x 500	110	65	1500 x 500	65	50	1200 x 500	50	40	
	4	2500 x 500	45	17	2300 x 500	40	17	1700 x 500	30	15	
	2	1500 x 500	15	4	1300 x 500	13	3	1200 x 500	12	3	
	Ø 50-100	Lmax 2500	40		Lmax 1700	28		Lmax 1700	24		
PFR 250		(L x B)	L > 300 B > 300	L > 100 B > 150	(L x B)	L > 300 B > 300	L > 100 B > 150	(L x B)	L > 300 B > 300	L > 100 B > 150	
	≥ 30	-	250	225	-	170	150	-	105	100	
	15	1750 x 1000	205	155	1250 x 1000	150	120	1000 x 800	90	85	
	10	2200 x 1000	170	80	1650 x 1000	130	65	1100 x 1000	85	53	
	6	2100 x 1000	100	34	1650 x 1000	80	28	1300 x 1000	60	23	
	4	1600 x 1000	50	17	1400 x 1000	45	14	1150 x 1000	36	12	
	Ø 60-200	Lmax 3500	125		Lmax 3000	100		Lmax 2500	70		
PFR 500		(L x B)	L > 400 B > 400	L > 110 B > 245	(L x B)	L > 400 B > 400	L > 110 B > 245	(L x B)	L > 400 B > 400	L > 110 B > 245	
	≥ 40	-	500	480	-	380	370	-	255	250	
	20	1800 x 1500	425	365	1650 x 1250	320	290	1400 x 1000	220	200	
	15	2250 x 1500	400	235	2050 x 1250	300	195	1750 x 1000	205	150	
	10	2500 x 1500	270	115	2350 x 1250	220	95	2150 x 1000	165	80	
	8	2300 x 1500	195	80	2250 x 1250	160	65	2150 x 1000	125	55	
	Ø 65-270	Lmax 4000	250		Lmax 3500	200		Lmax 3000	150		
PFR 1000		(L x B)	L > 500 B > 500	L > 145 B > 310	(L x B)	L > 500 B > 500	L > 145 B > 310	(L x B)	L > 500 B > 500	L > 145 B > 310	
	≥ 60	-	1000	985	-	845	835	-	650	645	
	30	2450 x 1500	860	710	2000 x 1500	730	620	1900 x 1250	565	515	
	25	2850 x 1500	830	535	2400 x 1500	705	475	2250 x 1250	550	410	
	20	3200 x 1500	745	365	2750 x 1500	640	320	2600 x 1250	510	290	
	15	3300 x 1500	500	215	2900 x 1500	445	195	2800 x 1250	380	175	
	Ø 100-300	Lmax 4500	500		Lmax 4000	400		Lmax 3500	300		
PFR 1500		(L x B)	L > 800 B > 800	L > 170 B > 400	(L x B)	L > 800 B > 800	L > 170 B > 400	(L x B)	L > 800 B > 800	L > 170 B > 400	
	≥ 80	-	1500	1460	-	1420	1200	-	1020	980	
	50	3000 x 1200	1460	1250	2500 x 1200	1200	1050	2000 x 1200	960	900	
	30	3500 x 1200	980	430	3250 x 1200	900	390	2500 x 1300	780	350	
	20	3500 x 1400	760	310	3000 x 1600	750	290	2500 x 1750	695	270	
	15	3000 x 1500	540	195	3000 x 1500	530	180	2500 x 1400	420	160	
	Ø 150-350	Lmax 5000	750		Lmax 4500	700		Lmax 3500	600		
PFR 2000		(L x B)	L > 800 B > 800	L > 170 B > 500	(L x B)	L > 800 B > 800	L > 170 B > 500	(L x B)	L > 800 B > 800	L > 170 B > 500	
	≥ 80	-	2000	1950	-	1650	1600	-	1300	1250	
	50	3250 x 1500	1950	1600	2500 x 1500	1600	1350	2000 x 1500	1250	1150	
	30	3500 x 1500	1350	550	3250 x 1500	1150	500	2500 x 1500	1000	450	
	20	3500 x 2000	1100	400	3000 x 2000	1000	375	2500 x 2000	900	350	
	15	3000 x 1500	650	250	3000 x 1500	600	230	2000 x 1500	550	200	
	Ø 100-350	Lmax 5000	1000		Lmax 4500	900		Lmax 4000	800		

ask our sales

QPM permanent lifting magnets



REMA QPM Neodymium permanent lifting magnets are suitable for lifting and transporting flat and cylindrical ferromagnetic materials ("magnetically supported as steel").

Properties

- Safety factor 3.5.
- High-quality Neodymium magnet material [NdFeB].
- Virtually no residual magnetism after decoupling prevents accidents.
- Simple and light lever operation with safety button.
- V-groove makes it possible to hoist cylindrical workpieces next to flat surfaces.
- Compact and robust construction with a large lifting eye.

Type selection:

- Choose the type of magnet to match the load to be lifted.
- Important features are the thickness, weight, size of the magnetic surface, material specification, surface structure, air gap and symmetrical load.

Application:

- REMA QPM permanent lifting magnets can be used as grabs in lifting and hoisting applications for horizontal and vertical materials handling in stores, steel construction manufacturing plants, machine and assembly bays etc.

IMPORTANT:

- Never exceed the safe workload.
- The full lifting force is only achieved if the surface of the steel plate to be lifted (St 37k and 25 mm thick) is processed, smooth and clean.
- Note that only one plate is lifted at a time when lifting thin sheets from a stack.
- Note the "peeling action" when lifting thin plates, these will bend and can become detached from the lifting magnet.
- Never let a lifting magnet come down hard on the ground.
- It is forbidden to be under the load of a lifting magnet, no persons should be put in danger while working with lifting magnets.
- Never lift loads on which loose objects are located.
- Do not lift uneven and porous workpieces.
- Surface must be dry, clean, oil and grease free.
- Lifting magnets only start on company-safe cranes and load hooks etc.
- Prevent shock loads during lifting and place the load in a controlled manner.
- Always check the quality of the control knob on the handle, guide and safety pin before use.
- Have the lifting magnet inspected and inspected by an authorized person or body every year.

Norm:

- EN12100-1/2, EN13155

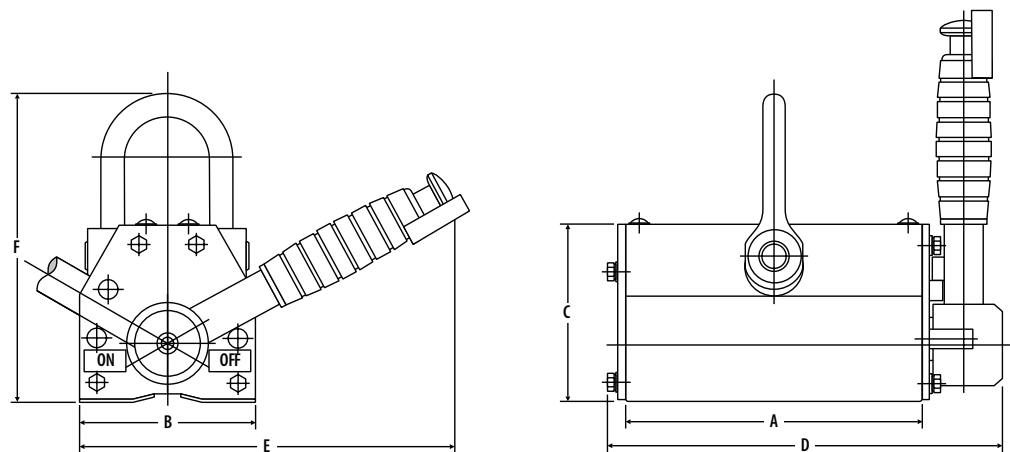

Type	S.W.L. (kg)	A (mm)	B (mm)	C (mm)	D (mm)	E (mm)	F (mm)	Lever length (mm)	Weight (kg)	ProductId
QPM-100	100	84	62	67	130	150	116	84	2.6	3610001
QPM-300	300	154	92	91	206	195	160	154	9.6	3610003
QPM-600	600	224	122	117	285	254	213	196	23.0	3610006
QPM-1000	1000	250	176	163	322	372	288	264	54.0	3610010

QPM capacity table

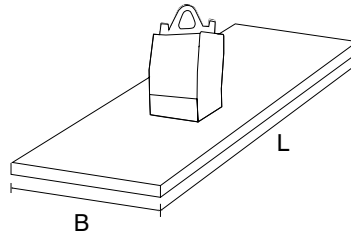

Safe working load limit for flat steel sheets (S 235 JR [ST-37])

Type	Material thickness (mm)	clean and smooth surface air gap 0.1 mm			rusty / hot rolled surface air gap 0.1 - 0.3 mm			irregular and rough surface air gap 0.3 - 0.5 mm		
		Max. dim. (mm)	WLL (kg) for plate dimensions below		Max. dim. (mm)	WLL (kg) for plate dimensions below		Max. dim. (mm)	WLL (kg) for plate dimensions below	
		(L x B)	L > 150 B > 150	L > 62 B > 116	(L x B)	L > 150 B > 150	L > 62 B > 116	(L x B)	L > 300 B > 300	L > 92 B > 192
QPM-100	≥ 20	-	100	80	-	50	46	-	-	-
	15	800 x 600	88	60	700 x 500	45	40	-	-	-
	10	500 x 400	55	40	400 x 300	35	30	-	-	-
	4	300 x 300	20	12	300 x 300	18	10	-	-	-
	Ø 70	Lmax 1000	30		-	-		-	-	
QPM-300	≥ 30	-	300	216	-	150	145	-	108	108
	15	1500 x 1500	264	168	1000 x 700	138	126	1000 x 700	102	95
	10	2000 x 1500	204	108	1500 x 1000	132	78	1000 x 1000	96	66
	5	2000 x 1000	114	36	1500 x 1000	78	30	1000 x 1000	66	24
	Ø 90	Lmax 2000	100		-	-		-	-	
QPM-600	≥ 40	-	600	480	-	380	330	-	282	244
	20	2000 x 1500	560	370	1500 x 1200	350	290	1400 x 1000	264	228
	10	2000 x 1500	318	132	2000 x 1250	240	108	1500 x 1000	198	96
	8	2000 x 1500	260	100	2000 x 1300	215	83	1500 x 1000	168	78
	Ø 110	Lmax 2600	200		Lmax 2000	160		Lmax 1500	120	
QPM-1000	≥ 60	-	1000	995	-	810	790	-	640	605
	30	2000 x 1500	965	515	2000 x 1400	780	450	2100 x 1100	620	400
	25	2100 x 1800	880	390	2000 x 1600	720	340	2000 x 1000	590	305
	20	2100 x 1800	715	270	2000 x 1600	600	230	2000 x 1100	510	215
	15	2000 x 1600	375	155	2000 x 1400	350	145	1700 x 1100	325	135
	10	2000 x 1600	270	80	2000 x 1400	230	70	1600 x 1100	215	70
	Ø 120	Lmax 3400	300		-	-		-	-	

PK/MK compact hand magnets



REMA PK and MK hand magnets are an indispensable tool in places where a lot of steel plates are used.

Properties

- GS-approved.
- Oil and grease have little influence on the magnetic force.
- The carrying handle is robust, ergonomic and plastic-coated.
- It is easy to detach the magnet from the workpiece by pressing down the handle or lever at the crane magnets, the leaf spring pushing the magnet loose without damaging the workpiece.
- After releasing the magnet, the workpieces are not magnetic.
- PK type is equipped with a plastic housing.
- Safety factor 2.

Application

- Horizontally or vertically stored blank steel sheets from stock to the workplace.
- Safe manoeuvring of steel sheets on machine.
- Lifting and transporting pieces of steel sheet after cutting.

Norm:

- EN12100-1/2, EN13155



Type	S.W.L. (kg)	Pulling force (kg)	Plate thickness (mm)	L x B (mm)	Weight (kg)	ProductId
PK-60	60	35	= 1-2	160 x 150	1.4	3604000
MK-120	120	70	= 1-2	140 x 84	1.4	3604001
MK-170	170	100	= 1-4	140 x 116	1.7	3604003
MK-300	300	180	>2	160 x 180	3.5	3604005

MK-250KS and MK-500KS compact crane magnets



REMA MK-250KS and MK-500KS are suitable for both vertical and horizontal lifting and transporting steel plates, allowing the steel plate can be rotated, which is an advantage in vertical storage. Both types are suitable for lifting steel sheets from 4 mm thick. With 20 mm thick steel plates the maximum lifting force is achieved. A lifting magnet is sufficient for steel sheets with a size of 1 x 2 m. For steel plates of 1.5 x 3 m two lifting magnets with a crossbar are required.

Properties

- Tiltable lifting eye.
- Can be used where high safety requirements apply and / or the surface of the steel plate is not 100% smooth or clean.

IMPORTANT!

- The full lifting force is only achieved if the surface of the steel plate to be lifted (St 37k and 25 mm thick) is processed, smooth and clean.
- Never exceed the safe workload.
- Hand magnets have safety factor 2.
- Crane magnets have safety factor 3.
- It is forbidden to be under the load of a crane magnet.

Norm:

- EN12100-1/2, EN13155

Type	S.W.L. (kg)	Pulling force (kg)	Plate thickness (mm)	L x B (mm)	Weight (kg)	ProductId
MK-250KS	250	100	>4	290 x 125	7.5	3604007
MK-500KS	300	125	>4	290 x 180	10.5	3604009