

REMA Anschlagpunkte (Güteklasse 10)

124

REMA Anschlagpunkte (Güteklasse 8)

129

REMA Anschlagpunkte (DIN 580)

132

REMA Anschlagwirbel mit Spannbügel C806X (Güteklasse 10)

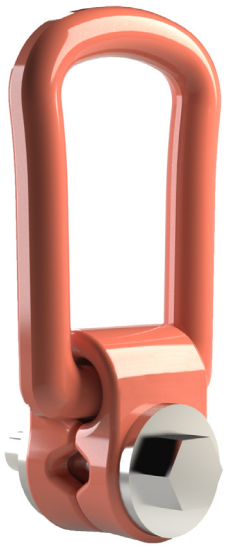

Merkmale

- 360 ° drehbar, 90 ° klappbar und tragfähig.
- Unter Last nicht drehbar.
- 4-fache Sicherheit in Lastrichtung.
- Nach EN 1677-1.

Norm:

- GS-OA 15-04 / EN1677

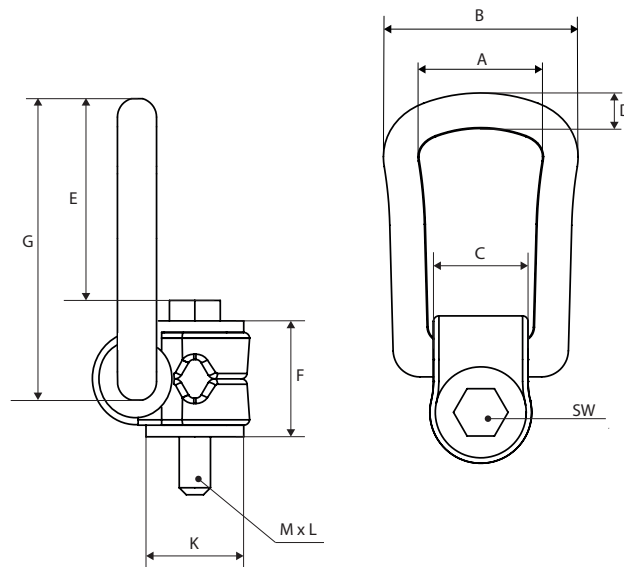

Typ	Tragfähigkeit (kg)	A (mm)	B (mm)	C (mm)	D (mm)	E (mm)	G (mm)	K (mm)	M (mm)	L (mm)	SW (mm)	Gewicht (kg/st/m)	Artikel-Nr.
C806X-M8x15-0.3T	300	34	57	24	10	43	78	25	M8	15	13	0,275	2611208
C806X-M10x15-0.63T	630	34	57	24	10	42	78	25	M10	15	17	0,290	2611210
C806X-M12x23-1.0T	1.000	38	66	30	13.5	40	85	32	M12	23	19	0,500	2611212
C806X-M16x24-1.5T	1.500	38	66	30	13.5	38	85	32	M16	24	24	0,510	2611216
C806X-M20x31-2.5T	2.500	55	87	48	16	54	111	45	M20	31	30	1,250	2611220
C806X-M24x37-4.0T	4.000	55	87	48	16	51	111	45	M24	37	36	1,300	2611224
C806X-M30x45-5.0T	5.000	66	109	54	22.5	62	145	60	M30	45	46	3,250	2611230
C806X-M36x50-7.0T	7.000	66	109	54	22.5	60	145	60	M36	50	55	3,300	2611236
C806X-M42x75-10T	10.000	78	136	62	28	86	190	70	M42	75	65	6,500	2611242
C806X-M42x63-15T	15.000	97	169	68	36	121	242	85	M42	63	65	11,200	2611243
C806X-M48x71-20T	20.000	97	169	68	36	117	242	95	M48	71	75	11,600	2611248

REMA Anschlagwirbel mit Gelenk C811X/C812X (Güteklasse 10)



C811X



C812X

Merkmale

- 360° drehbar, faltbar.
- Typ C811 verfügt über eine 4-fache Sicherheit in Lastrichtung.
- Typ C812 verfügt über eine 5-fache Sicherheit in Lastrichtung.
- Unter Last nicht drehbar.
- Nach EN 1677-1.

Norm:

- GS-OA 15-04 / EN1677

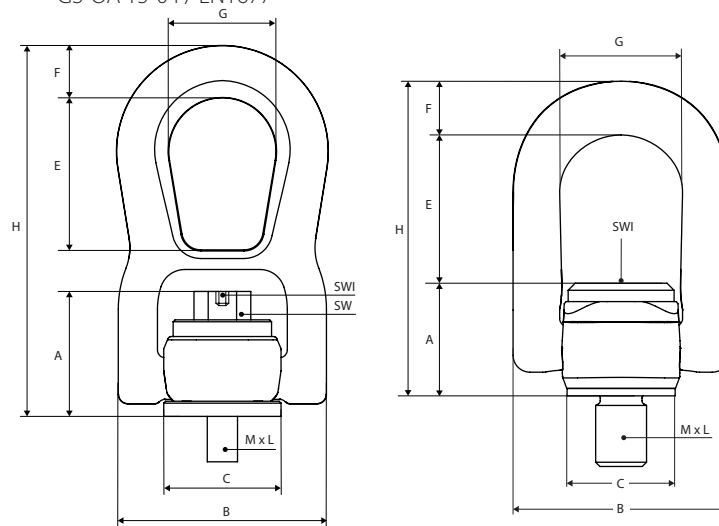

Typ	Tragfähigkeit (kg)	A (mm)	B (mm)	C (mm)	E (mm)	F (mm)	G (mm)	H (mm)	M (mm)	L (mm)	SW (mm)	SWI (mm)	Gewicht (kg/st/m)	Artikel-Nr.
C811X-M8x12-0.3T	300	33.5	56	30	40	14	28	99	M8	12	13	5	0,375	2611308
C811X-M10x15-0.6T	600	34.5	56	30	40	14	28	99	M10	15	17	6	0,375	2611310
C811X-M12x18-1.0T	1.000	35.5	56	30	40	14	28	99	M12	18	19	7	0,375	2611312
C811X-M14x21-1.3T	1.300	46	74.5	47	55	18	38	135.5	M14	21	22	7	1,030	2611314
C811X-M16x25-1.6T	1.600	46.5	74.5	47	55	18	38	135.5	M16	25	24	10	1,040	2611316
C811X-M18x27-2.0T	2.000	47	74.5	47	55	18	38	135.5	M18	27	27	10	1,070	2611318
C811X-M20x30-2.5T	2.500	43	79	45	55	25	38	138	M20	30	24	10	1,080	2611320
C811X-M22x33-3.0T	3.000	63.5	106	62	84	25	56	198.5	M22	33	32	12	4,000	2611322
C811X-M24x36-4.0T	4.000	64.5	106	62	84	25	56	198.5	M24	36	36	14	4,000	2611324
C811X-M27x40-5.0T	5.000	66.5	106	62	84	25	56	198.5	M27	40	41		4,000	2611327
C811X-M30x45-6.3T	6.300	68	106	62	84	25	56	198.5	M30	45	46	17	4,000	2611330
C812X-M36x54-10T	10.000	80	150	76.5	108	32	85	220	M36	54	-	17	6,000	2611336
C812X-M42x63-12.5T	12.500	80	150	76.5	108	32	85	220	M42	63	-	17	6,000	2611342
C812X-M48x68-17T	17.000	90	176	95	128	39	100	257	M48	68	-	17	10,500	2611348
C812X-M56x78-25T	25.000	90	176	95	128	39	100	257	M52	78	-	17	10,500	2611356
C812X-M64x90-35T	35.000	105	200	110	126	46	113	277	M64	90	-	19	16,300	2611364

REMA Anschlagwirbel C800X (Güteklasse 10)



Merkmale

- Kugelgelagerter und unter Last 360° drehbarer Anschlagpunkt.
- Hochfeste Anschlagöse 180° klappbar.
- Nach EN 1677-1.

Norm:

- GS-OA 15-04 / EN1677

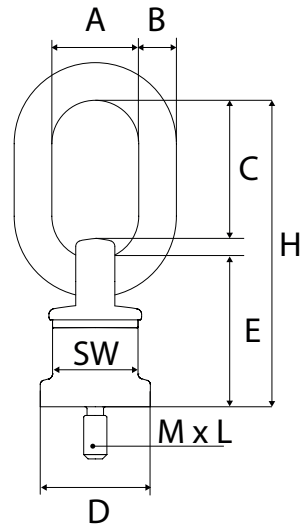

Typ	Tragfähigkeit (kg)	A (mm)	B (mm)	C (mm)	D (mm)	E (mm)	H (mm)	M x L (mm)	SW (mm)	Gewicht (kg/st/m)	Artikel-Nr.
C800X-M8x18-0.3T	300	30	13	46	38	50	105	8 x 16	30	0.48	2611108
C800X-M10x18-0.5T	500	30	13	46	38	50	105	10 x 18	30	0.48	2611110
C800X-M12x18-0.7T	700	30	13	46	38	50	105	12 x 18	30	0.50	2611112
C800X-M16x20-1.4T	1.400	30	13	46	38	50	105	16 x 20	30	0.53	2611116
C800X-M20x30-2.5T	2.500	34	16	57	50	61	131	20 x 30	40	1.05	2611120
C800X-M24x30-4.0T	4.000	40	18	70	58	68	153	24 x 30	48	1.63	2611124
C800X-M30x35-6.7T	6.700	45	22	65	80	71	156	30 x 35	70	2.85	2611130
C800X-M36x54-10T	10.000	50	23	91	90	86	200	36 x 54	80	4.62	2611136
C800X-M42x63-12.5T	12.500	50	23	91	90	86	200	42 x 63	80	5.20	2611142
C800X-M48x72-12.5T	12.500	50	23	91	90	86	200	48 x 72	80	5.20	2611148

REMA Ringschraube mit Schlüssel C907X+KEY (Güteklasse 10)



Merkmale

- 360° drehbar.
- Handfest anziehen.
- Unter Last nicht drehbar.
- Nach EN 1677-1

Norm:

- GS-OA 15-04 / EN1677

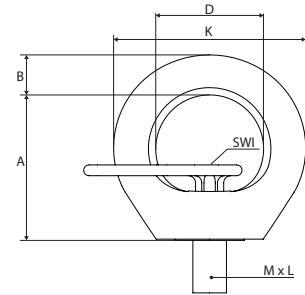
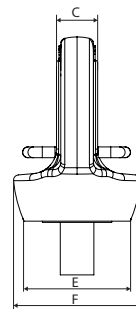

Typ	Tragfähigkeit (kg)	A (mm)	B (mm)	C (mm)	D (mm)	E (mm)	F (mm)	K (mm)	M x L (mm)	SWI (mm)	Gewicht (kg/st/m)	Artikel-Nr.
C807X+KEY-M8x12-0.3T	300	35	11	9	25	25	30	47	M8 x 12	6	0.300	2611408
C807X+KEY-M10x15-0.4T	400	35	11	9	25	25	30	47	M10 x 16	6	0.300	2611410
C807X+KEY-M12x23-0.75T	750	43	12.5	11.5	30	30	36.5	55.5	M12 x 18	7	0.460	2611412
C807X+KEY-M16x24-1.5T	1.500	49.5	14.5	15.7	35	35	41.8	64.5	M16 x 24	8	0.900	2611416
C807X+KEY-M20x30-2.3T	2.300	58	16	18	40	42	51.5	74.5	M20 x 30	10	1.150	2611420
C807X+KEY-M24x36-3.2T	3.200	69	20.5	22	49	50	58	90	M24 x 36	12	2.050	2611424
C807X+KEY-M30x45-4.5T	4.500	86	25.5	28	60	66	73	111	M30 x 43	17	3.120	2611430
C807X+KEY-M36x54-7.0T	7.000	107	32	32	74	75	96.5	135	M36 x 54	22	6.700	2611436
C807X+KEY-M42x63-9.0T	9.000	120	38	40.5	82	85	110	158	M42 x 64	24	9.500	2611442
C807X+KEY-M48x72-12T	12.000	139	43	44	95	100	124.5	179	M48 x 72	27	13.550	2611448

REMA Ringmutter C810FX (Güteklasse 10)



Merkmale

- 360° drehbar.
- In Lastrichtung handfest anziehen.
- Unter Last nicht drehbar.
- Mindestklasse 10.9.
- Nach EN 1677-1

Norm:

- GS-OA 15-04 / EN1677

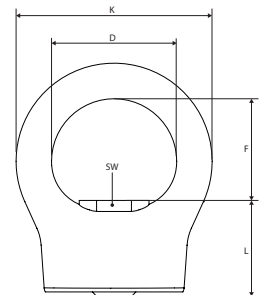
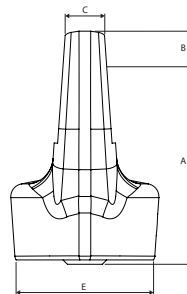

Typ	Tragfähigkeit (kg)	A (mm)	B (mm)	C (mm)	D (mm)	E (mm)	F (mm)	K (mm)	M x L (mm)	SW (mm)	Gewicht (kg/st/m)	Artikel-Nr.
C810FX-M8-0.3T	300	44.5	8	10	29	32	23	45	M8 x 21.5	13	0.17	2611508
C810FX-M10-0.4T	400	44.5	8	10	29	32	23	45	M10 x 21.5	14	0.20	2611510
C810FX-M12-0.75T	750	53.5	11	11	34	44	27	56	M12 x 26.5	16	0.39	2611512
C810FX-M16-1.5T	1.500	59.5	13	14.5	39	56	29	65	M16 x 30.5	21	0.69	2611516
C810FX-M20-2.3T	2.300	67	14	17	42	58	34	70	M20 x 33.0	26	0.71	2611520
C810FX-M24-3.2T	3.200	80	18	19	52	73	40	88	M24 x 40.0	30	1.70	2611524
C810FX-M30-4.5T	4.500	101	22	27	62	80	50	106	M30 x 51.0	36	2.44	2611530

REMA Transportring C835X (Güteklasse 10)



Norm:

- GS-OA 15-04 / EN1677

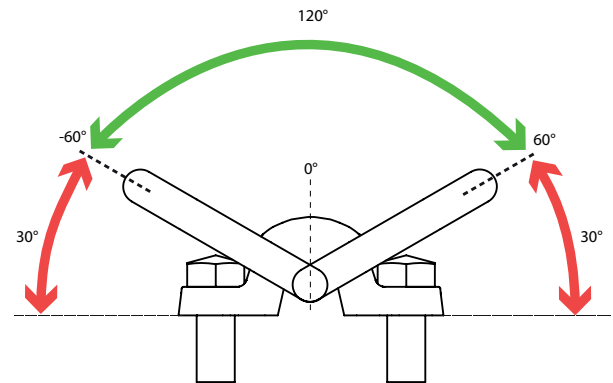
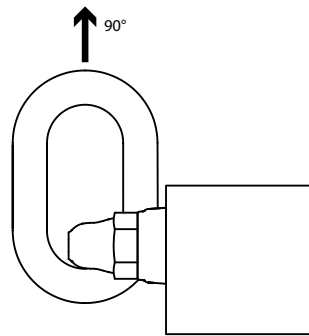
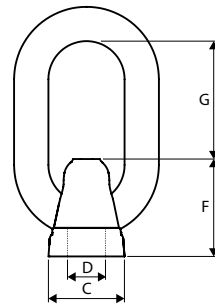
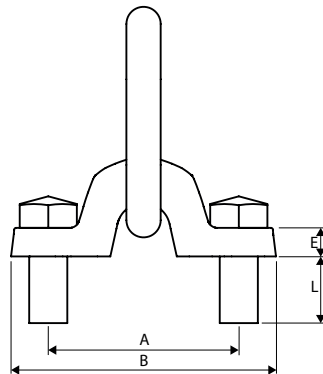

Typ	Tragfähigkeit (kg)	A (mm)	B (mm)	C (mm)	D (mm)	E (mm)	F (mm)	G (mm)	L (mm)	Abmessung Öse (mm)	Gewicht (kg/st/m)	Artikel-Nr.
C835-M20-4000KG	4.000	100	138	39	21.5	15	57	61	35	18 x 85 x 40	1.20	2676110
C835-M24-6700KG	6.700	120	165.5	48	25.5	19	63	87	41	22 x 115 x 50	2.50	2676113
C835-M30-10T	10.000	160	216	62	31.5	25	78	106	45	26 x 140 x 65	7.10	2676116
C835-M36-16T	16.000	177	250	69	37	29	90	112	61	32 x 150 x 70	7.50	2676119

REMA Anschlagwirbel mit Gelenk DSR/DSS UP (Güteklasse 8)



DSR-up



DSS-up

Der Doppelwirbelring wurde speziell entworfen um das Heben unter Rotation zu gewährleisten. Sein doppeltes Gelenk ermöglicht es, diesen perfekt zum Anschlaggeschirr auszurichten.
 360° drehbar.
 180° schwenkbar.
 Orange lackiert.

Norm:

- EN1677, ASME-B30,26

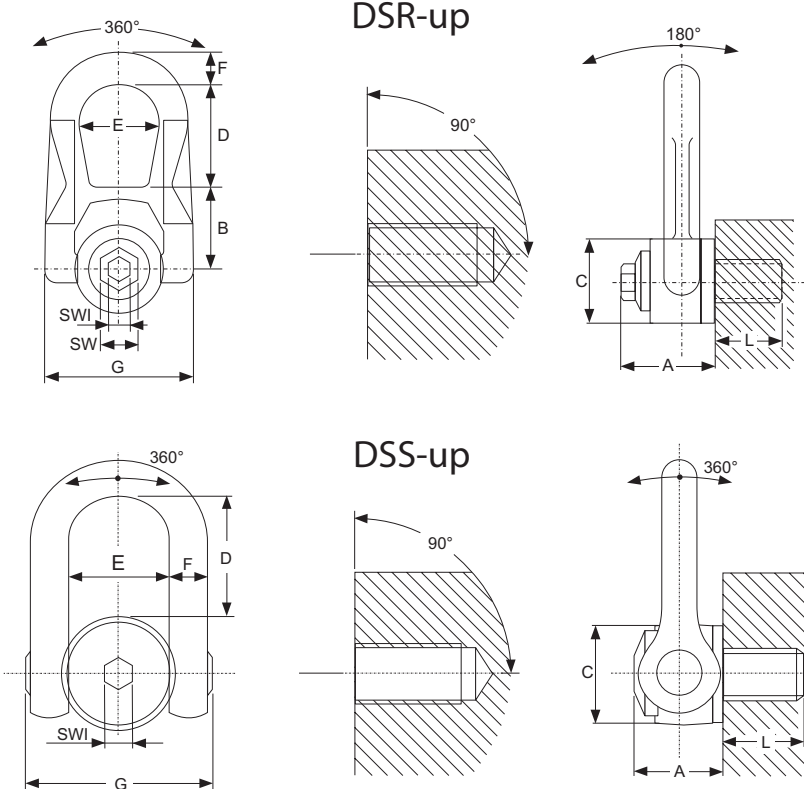

Typ	Tragfähigkeit (kg)	A (mm)	B (mm)	C (mm)	D (mm)	E (mm)	F (mm)	G (mm)	L (mm)	SWI (mm)	SW (mm)	Gewicht (kg/st/m)	Artikel-Nr.
DSR-UP M8/400KG	400	33	30	30	38	27	14	53	15	8	16	0.30	2674108
DSR-UP M10/700KG	700	33	30	30	38	27	14	53	18	8	16	0.30	2674110
DSR-UP M12/1050KG	1.050	33	30	30	38	27	14	53	21	8	16	0.30	2674112
DSR-UP M14/1400KG	1.400	45	40	45	53	38	17	76	23	8	20	0.90	2674114
DSR-UP M16/2000KG	2.000	45	40	45	53	38	17	76	27	8	20	0.90	2674116
DSR-UP M18/2300KG	2.300	45	40	45	53	38	17	76	27	8	20	0.90	2674118
DSR-UP M-20/2500KG	2.500	45	40	45	53	38	17	76	30	8	20	0.90	2674120
DSR-UP M-22/3500KG	3.500	62	55	60	83	55	25	115	33	14	24	2.60	2674122
DSR-UP M24/4400KG	4.400	62	55	60	83	55	25	115	36	14	24	2.60	2674124
DSR-UP M30/6300KG	6.300	62	55	60	83	55	25	115	45	14	24	2.70	2674130
DSR-UP M36/8000KG	8.000	80	77	78	98	71	26	141	54	14	30	5.40	2674136
DSR-UP M42/8500KG	8.500	80	77	78	98	71	26	141	63	14	30	5.50	2674142
DSS-UP M36/11000KG	11.000	61	31	70	104	73	149	33	54	19	-	5.50	2674236
DSS-UP M42/13.000KG	13.000	61	31	70	104	73	149	33	68	19	-	11.00	2674242
DSS-UP M56/22.000KG	22.000	79	38	90	125	91	182	45	78	19	-	11.3	2674256
DSS-UP M64/25.000KG	25.000	79	38	95	125	91	182	45	90	19	-	12.2	2674264

REMA Ringschraube EOB (Güteklasse 8)



Die hochfeste Ringschraube EOB ist als Hebeöse für Maschinenteile verwendbar. Ringschrauben dürfen nur händisch festgezogen werden. Tragfähigkeit, bei max 60°.

Norm:

- EN1677

Typ	Tragfähigkeit (kg)	A (mm)	B (mm)	C (mm)	D (mm)	M (mm)	Gewicht (kg/st/m)	Artikel-Nr.
EOB08	400	34	7	20	24	M8 x 1,25	0.05	2675108
EOB10	700	38	8	22	30	M10 x 1,50	0.08	2675110
EOB12	1000	47	10	26	36	M12 x 1.75	0.14	2675112
EOB14	1200	57	14	29	40	M14 x 2.00	0.25	2675114
EOB16	1500	65	14	35	55	M16 x 2.00	0.36	2675116
EOB18	2000	65	14	35	54	M18 x 2.00	0.38	2675118
EOB20	2500	73	16	39	59	M20 x 2.50	0.55	2675120
EOB24	4000	95	20	54	84	M24 x 3.00	1.12	2675124
EOB27	5000	95	20	54	84	M27 x 3.00	1.18	2675127
EOB30	6000	108	24	59	100	M30 x 3.50	1.84	2675130
EOB36	8000	118	25	67	118	M36 x 4.00	2.44	2675136
EOB42	10.000	139	31	79	135	M42 x 4.50	3.97	2675142

REMA Ringschraube DIN580 (Güteklasse 8)



Die hochfeste Ringschraube EOB ist als Hebeöse für Maschinenteile verwendbar. Ringschrauben dürfen nur händisch festgezogen werden. Tragfähigkeit, bei max 60°.

Norm:

- EN1677, DIN580

Typ	Tragfähigkeit (kg)	A (mm)	B (mm)	C (mm)	D (mm)	M (mm)	Gewicht (kg/st/m)	Artikel-Nr.
DIN580-G8-M8	400	34	7	20	13	M8 x 1,25	0.05	2675308
DIN580-G8-M10	700	38	8	22	17	M10 x 1,50	0.07	2675310
DIN580-G8-M12	1000	47	10	26	21	M12 x 1.75	0.13	2675312
DIN580-G8-M16	1500	64	14	35	27	M16 x 2.00	0.34	2675316
DIN580-G8-M20	2500	73	16	39	30	M20 x 2.50	0.52	2675320
DIN580-G8-M24	4000	95	20	54	36	M24 x 3.00	0.99	2675324

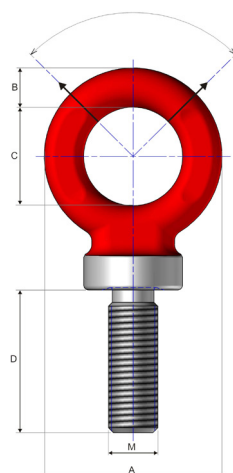

Belastbarkeitsrichtungen

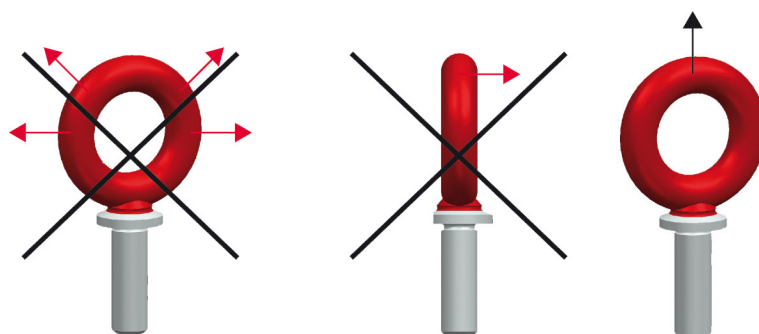

REMA Anschweißhaken AH (Güteklasse 8)



Merkmale

- Zulässige Tragkraft 1.000 bis 8.000 kg.
- Anschweißhaken sind universell verwendbar auf LKW's, Anhänger, Erdbaugeräte, Traversen usw.
- Die Haken können verschweißt werden ohne jegliche Nachbehandlung.
- Die REMA Anschweißhaken haben eine stabile Sicherheitsfalle.
- Die Haken sind standardmäßig rot pulverbeschichtet.

Norm:

- EN1677-1, EN25817, EN287-1

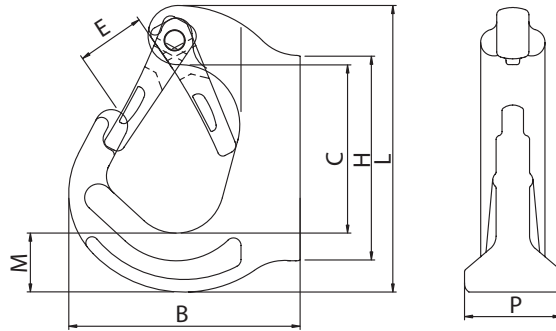

Typ	Tragfähigkeit (kg)	B (mm)	C (mm)	E (mm)	H (mm)	L (mm)	M (mm)	P (mm)	Gewicht (kg/st/m)	Artikel-Nr.
AH-1.0	1000	79	65	25	92	102	25	25.0	0.5	2672501
AH-3.0	3000	105	75	29	116	128	30	36.0	1.2	2672503
AH-5.0	5000	131	97	36	159	171	45	42.5	2.5	2672505
AH-8.0	8000	136	94	36	159	177	44	51.0	3.3	2672507

REMA Anschweißöse C804 (Güteklasse 8)



Die REMA Anschweißöse (Güteklasse 8) ist hochfest und zum Anschweißen an Maschinenteilen oder Fahrzeugbauten. Sie ist ideal zum Einhängen von Anschlag- und Zurrmitteln. Dank der eingebauten Feder wird der Ring in jeder gewünschten Position gehalten.

Für die Schweißarbeiten gelten die Bestimmungen nach EN25817. Die Schweißarbeiten dürfen nur von einem Schweißer mit gültiger Qualifikation nach EN 287-1 durchgeführt werden.

Norm:

- EN1677

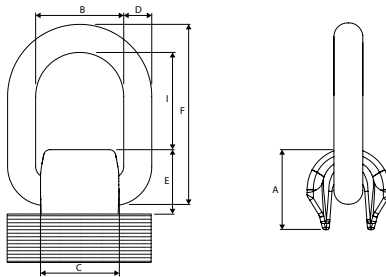

Typ	Tragfähigkeit (kg)	A (mm)	B (mm)	C (mm)	D (mm)	E (mm)	F (mm)	I (mm)	Gewicht (kg/st/m)	Artikel-Nr.
C80401M-1.12	1.120	35	41	36	13	28	66	40	0.39	2677101
C80402M-2	2.000	38	42	39	13	33	74	44	0.51	2677102
C80403M-3.15	3.150	42	45	43	17	34	80	49	0.70	2677103
C80405M-5.3	5.300	60	55	50	22	44	95	55	1.50	2677105
C80408M-8	8.000	70	70	65	26	53	108	70	2.60	2677108
C80415M-15	15.000	90	97	90	34	73	155	92	5.85	2677115

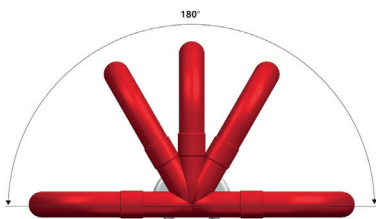

REMA Ringschraube G-8140



Material : Karbon Stahl, C15, DIN 580, Sicherheitsfaktor : Mindestbruchlast = 6-fache WLL.
Oberflächenbehandlung : Galvanisch verzinkt.

Norm:

- DIN582

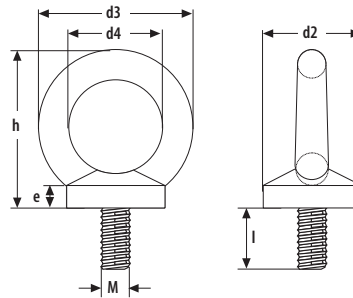

Typ	Tragfähigkeit (kg)	D2 (mm)	D3 (mm)	D4 (mm)	E (mm)	H (mm)	L (mm)	M (mm)	Gewicht (kg/st/m)	Artikel-Nr.
G8140-M8	140	20	36	20	6	36	13	8	0.06	3015001
G8140-M10	230	25	45	25	8	45	17	10	0.11	3015003
G8140-M12	340	30	54	30	10	53	20.5	12	0.18	3015005
G8140-M14	490	35	63	35	12	60	27	14	0.28	3015007
G8140-M16	700	35	63	35	12	62	27	16	0.28	3015009
G8140-M20	1200	40	72	40	14	71	30	20	0.43	3015011
G8140-M24	1800	50	90	50	18	90	36	24	0.84	3015013
G8140-M27	2500	50	90	50	18	90	36	27	1.22	3015015
G8140-M30	3200	65	108	60	22	109	45	30	1.66	3015017
G8140-M36	4600	75	196	70	26	128	54	36	2.65	3015019

REMA Ringmutter G-8142



Material : Karbon Stahl, C15, DIN 580, Sicherheitsfaktor : Mindestbruchlast = 6-fache WLL.
Oberflächenbehandlung : Galvanisch verzinkt.

Norm:

- DIN582

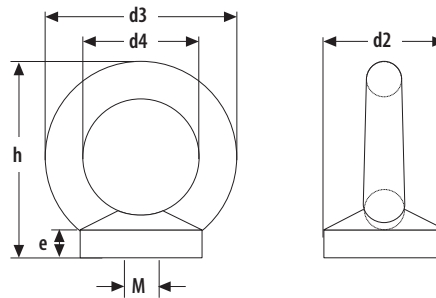

Typ	Tragfähigkeit (kg)	D2 (mm)	D3 (mm)	D4 (mm)	E (mm)	H (mm)	M (mm)	Gewicht (kg/pce/m)	Artikel-Nr.
G8142-M8	140	20	36	20	8.5	36	8	0.6	3017001
G8142-M10	230	25	45	25	10	45	10	0.1	3017003
G8142-M12	340	30	54	30	11	53	12	0.16	3017005
G8142-M14	490	35	63	35	13	62	14	0.24	3017007
G8142-M16	700	35	63	35	13	62	16	0.24	3017009
G8142-M20	1200	40	72	40	16	71	20	0.36	3017011
G8142-M24	1800	50	90	50	20	90	24	0.71	3017013
G8142-M27	2500	50	90	50	20	90	27	1.1	3017015
G8142-M30	3200	65	108	60	25	109	30	1.32	3017017
G8142-M36	4600	75	126	70	30	128	36	2.08	3017019