

## REMA X-BL Battery-powered electric chain hoist

### Product information



The REMA X-BL battery-powered chain hoist offers the flexibility of a manual chain hoist, the power of an electric hoist, and the mobility of a cordless tool. The battery-powered chain hoist is surprisingly versatile; it has its own power source, is lightweight, compact yet professionally powerful, and can be used in a wide range of industries where mobility and flexibility are crucial.

In short: wherever mobile lifting is required, the REMA X-BL battery-powered chain hoist is your ideal partner.

#### Properties

- Brake that holds the load at any desired height.
- Limit switches for highest and lowest hook positions.
- Power supply 18/36 V.
- Galvanized load chain, Class DAT (Grade 8).
- In case of overload, the hooks will gradually bend and do not suddenly break.
- 1 speed.
- Brushless DC electric chain hoist
- Lion battery 18 V 4.0 Ah
- Thermal overload protection

#### Standard delivery

- 3 m lifting height (maximum distance between top and bottom hook).
- 1.8 m control cable.
- Limit switches highest and lowest hook position.
- Push-button 18/36 V control unit.
- Plastic chain bucket for 6 m lifting height.
- Incl. battery and battery charger

[... Read more](#)

**Material:** Steel

**Marking:** According to standard, CE-marked

**Standard:** EN 12100, EN 14492, EN 60204-32, EN 818-7

## REMA X-BL Battery-powered electric chain hoist

### Blueprint

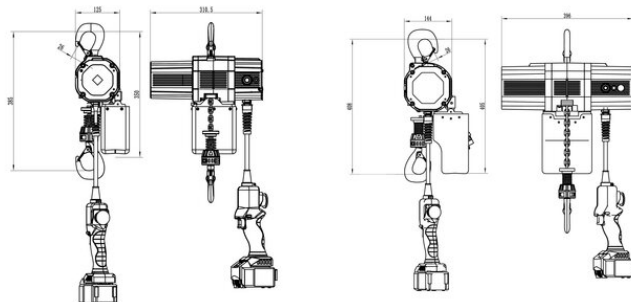

### Technical data

Part code	WLL ton	Size	Lifting height m	Lifting speed m/min	Number of falls	Model	Motor kW	Protection	Duty rating % ED	Duty group of hoist FEM 9.511	Load chain mm	Construction height mm	Standard chain bag for lifting height m	table.heading.operation-voltage-vdc	Weight kg
0040001-3	0.25	310x110x115	3	3.5	1	X-BL/250KG/3M	0.32	IP54	40	2m	4 x 12	335	6	18	12
0040001-6	0.25	311x110x115	6	3.5	1	X-BL/250KG/6M	0.32	IP54	40	2m	4 x 12	335	6	18	18
0040002-3	0.5	400x130x135	3	4	1	X-BL/500KG/3M	0.85	IP54	40	2m	5 x 15	345	6	36	15.5
0040002-6	0.5	400x130x135	6	4	1	X-BL/500KG/6M	0.85	IP54	40	2m	5 x 15	345	6	36	21.5