

## Lever Hoist Elephant YA mini (Rema YAM)

---

### Product information



The Elephant YA mini lever hoist is compact and a very low own weight. The required manual effort on the short handle (180 mm) remains low because the YAM is equipped with a gear transmission. The ideal tool for assembly work such as hoisting, pulling and tensioning.

#### Features:

- Very low self weight (2,8 kg), compact.
- Hooks equipped with safety latches.
- Self locked brake holds the load at any desired height.
- Freewheel is possible in unloaded condition, by 1 operation.
- Hoist fitted with rubber anti-slip handle.
- In case of overload, the hooks will gradually bend and do not suddenly break off.
- Galvanized load chain Grade 10.

#### Standard delivery:

- 1,5 m lifting height (max. distance between top & bottom hooks).

#### Option:

- Available in other lifting heights.

... [Read more](#)

---

**Marking:** According to standard, CE-marked

**Standard:** EN 818-7, EN 13157

## Lever Hoist Elephant YA mini (Rema YAM)

### Blueprint

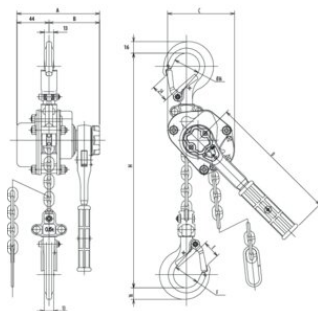

### Technical data

Part code	WLL ton	Lifting height m	Number of falls	Model	Load chain mm	Construction height mm	Hand force max. kg	A mm	B mm	C mm	D mm	E mm	F mm	H mm	Weight kg
0208002-1,5	0.5	1.5	1	YAM-500KG-1,5	4.3 x 12	240	35	113	69	92	180	24	36	240	2.8
0208002-3	0.5	3	1	YAM-500KG-3	4.3 x 12	240	35	113	69	92	180	24	36	240	3.4
0208002-4,5	0.5	4.5	1	YAM-500KG-4,5	4.3 x 12	240	35	113	69	92	180	24	36	240	4
0208002-6	0.5	6	1	YAM-500KG-6	4.3 x 12	240	35	113	69	92	180	24	36	240	4.6