

KG KRAANLOOPWIELEN

Ons leveringprogramma omvat:

- Kraanloopwielen volgens DIN15049 - 15074 - 15075 - 15078 en 15079
- Enkeflens kraanloopwielen volgens DIN1025.
- Met of zonder tandkrans.
- Tot een diameter van 300 mm.
- Stalen rondsels.

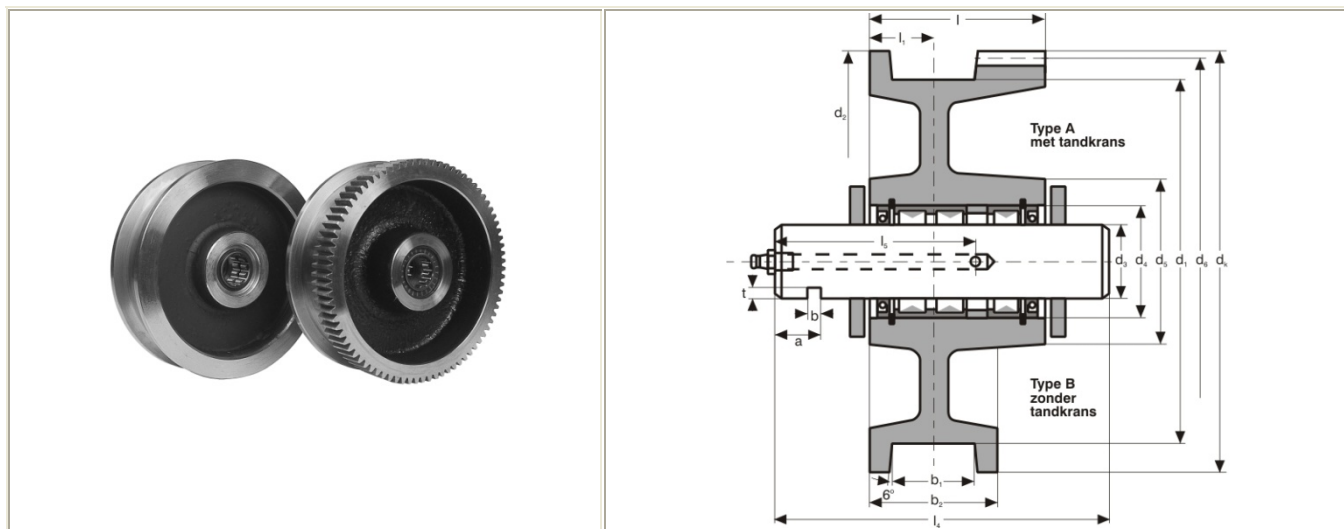

Wiel d1 h11	a (mm)	b (mm)	b ₁ ²⁾ (mm)	b ₂ (mm)	d ₂ (mm)	d ₃ (mm)	d ₄ (mm)	d ₅ (mm)	d ₆ (mm)	l (mm)	l ₁ (mm)	l ₄ (mm)	l ₅ (mm)	t (mm)	aantal lagers	tandkrans			gewicht kg/st		max wiellast (daN ³)
																m	z	dk	A	B	
160	25	8	60	80	186	40	62	85	180	95	40	190	110	7	2	2,5	72	185	11	9,5	2.600
																3	60	186			
200	25	8	60	80	232	40	62	117	225	95	40	190	110	7	3	3	75	231	18,5	17	4.000
									224							4	56	232			
250	25	8	60	80	274	50	80	142	264	120	40	210	120	8	3	3	88	270	31	26	5.600
									264							4	66	272			
300	25	8	65	90	336	50	80	152	330	120	45	210	8	3	3	3	110	336	44	38	6.750
									328							4	82	336			
315	25	8	75	100	348	55	85	167	340	140	50	265	140	9	3	4	85	348	56	50	7.100
400	25	8	75	100	432	60	90	197	424	140	50	265	140	9	4	4	106	432	88	73	9.700
500	25	10	85	110	540	70	110	160	528	170	55	285	150	10	4	6	88	540	145	114	17.000
630	25	10	95	120	680	80	120	180	664	200	60	335	160	10	4	8	83	680	240	186	21.000